

GSH HD157 FULL SURFACE ALUM. GEARED HINGE

Gallery™
specialty hardware ltd.



GallerySpecialty.com

1.800.267.1236

- Aluminum alloy with self-lubricating bearings
- Continuous Geared Full Surface Hinge with 1/16" (1.6mm) inset is Ideal for retrofit applications where original hinges have failed
- Can be used with any Standard Frame Without hinge preps.
- The Frame face must have a Flat surface at least 7/8" (22mm) wide.
- 83" length available in clear and dark bronze anodized
- Hinges are shorter than the Door height to avoid threshold or carpet Clearance problems
- Clearance required between the hinge edge of the Door and the Frame must be 1/32" (0.8mm)
- For 1-3/4" Doors. 48" maximum Door width. Up to 200 pounds high frequency and 400 pounds for medium frequency Doors.
- UL tested and approved for 90 minutes

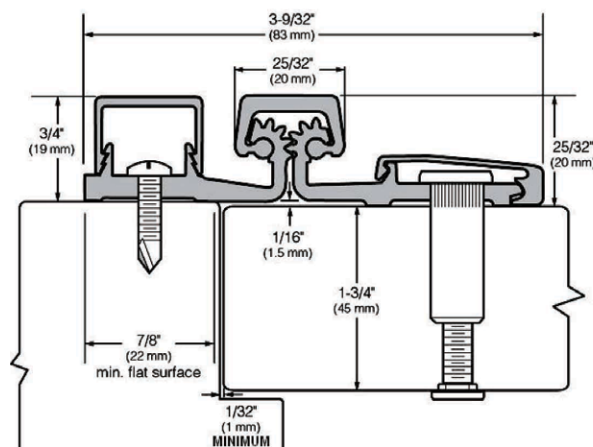

676 Petrolia Road, Toronto, ON, Canada M3J 2V2
Tel: 416.667.9593 Fax: 416.667.0806
Email: info@galleryspecialty.com

All product specifications are subject to change. For the most updated product features, contact our customer service department Toll Free at 1.800.267.1236

©2019 Gallery Specialty Hardware Ltd.