

GSH HD210 FULL SURFACE ALUM. GEARED HINGE

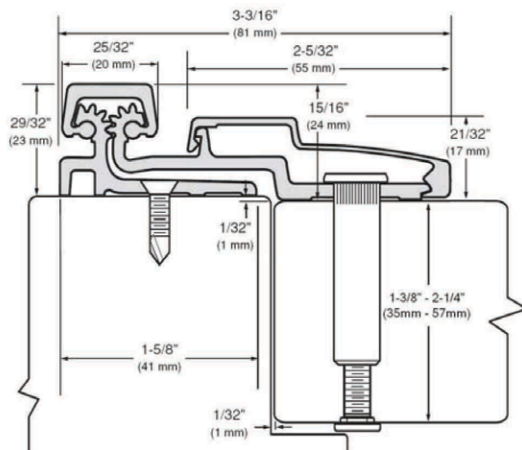

GallerySpecialty.com
1.800.267.1236



- Aluminum alloy with self-lubricating bearings
- Continuous Geared Full Surface Swing Clear Hinge with $1/32''$ (0.8mm) inset is Ideal for retrofit applications were original hinges have failed.
- Can be used with any Standard Frame Without hinge preps.
- The Frame face must have a Flat surface at least $1-5/8''$ (41mm) wide.
- 83" length available in clear and dark bronze anodized
- Hinges are shorter than the Door height to avoid threshold or carpet Clearance problems
- Clearance required between the hinge edge of the Door and the Frame must be $1/32''$ (0.8mm)
- For $1-3/4''$ Doors. 48" maximum Door width. Up to 200 pounds high frequency and 400 pounds for medium frequency Doors.
- UL tested and approved for 90 minutes

676 Petrolia Road, Toronto, ON, Canada M3J 2V2
Tel: 416.667.9593 Fax: 416.667.0806
Email: info@galleryspecialty.com

All product specifications are subject to change. For the most updated product features, contact our customer service department Toll Free at 1.800.267.1236

©2019 Gallery Specialty Hardware Ltd.